

BH FITNESS



Multistations

Архангельск (8182)63-90-72
Астана (7172)727-132
Астрахань (8512)99-46-04
Барнаул (3852)73-04-60
Белгород (4722)40-23-64
Брянск (4832)59-03-52
Владивосток (423)249-28-31
Волгоград (844)278-03-48
Вологда (8172)26-41-59
Воронеж (473)204-51-73
Екатеринбург (343)384-55-89
Иваново (4932)77-34-06

Ижевск (3412)26-03-58
Иркутск (395)279-98-46
Казань (843)206-01-48
Калининград (4012)72-03-81
Калуга (4842)92-23-67
Кемерово (3842)65-04-62
Киров (8332)68-02-04
Краснодар (861)203-40-90
Красноярск (391)204-63-61
Курск (4712)77-13-04
Липецк (4742)52-20-81
Киргизия (996)312-96-26-47

Магнитогорск (3519)55-03-13
Москва (495)268-04-70
Мурманск (8152)59-64-93
Набережные Челны (8552)20-53-41
Нижний Новгород (831)429-08-12
Новокузнецк (3843)20-46-81
Новосибирск (383)227-86-73
Омск (3812)21-46-40
Орел (4862)44-53-42
Оренбург (3532)37-68-04
Пенза (8412)22-31-16
Россия (495)268-04-70

Пермь (342)205-81-47
Ростов-на-Дону (863)308-18-15
Рязань (4912)46-61-64
Самара (846)206-03-16
Санкт-Петербург (812)309-46-40
Саратов (845)249-38-78
Севастополь (8692)22-31-93
Симферополь (3652)67-13-56
Смоленск (4812)29-41-54
Сочи (862)225-72-31
Ставрополь (8652)20-65-13
Казахстан (772)734-952-31

Сургут (3462)77-98-35
Тверь (4822)63-31-35
Томск (3822)98-41-53
Тула (4872)74-02-29
Тюмень (3452)66-21-18
Ульяновск (8422)24-23-59
Уфа (347)229-48-12
Хабаровск (4212)92-98-04
Челябинск (351)202-03-61
Череповец (8202)49-02-64
Ярославль (4852)69-52-93

Адрес сайта: bhfitness.nt-rt.ru || эл. почта: bfm@nt-rt.ru

L480_4 Stations

Dimensions (L x W x H): 335 x 210 x 233 cm

Weight: 638,20 kg

- Machine comprises a high pulley, a double pulley lat pulldown, a triceps post and 1/2 cable pulls.
- Natural, precise and supple movement thanks to an extensive biomechanical study.
- Graphic information panel showing the muscles used and the correct positions to adopt.
- Polycarbonate fairing for better protection.



L485_5 Stations

Dimensions (L x W x H): 335 x 490 x 240 cm

Weight: 820 kg

- Machine comprises a high pulley, a double pulley lat pulldown, a triceps post and a cable pull.
- The 5 stations are loaded to 90 kg.
- Natural, precise and supple movement thanks to an extensive biomechanical study.
- Graphic information panel showing the muscles used as well as the correct positions to adopt.
- Polycarbonate fairing for better protection.



L480x2_8 Stations

Dimensions (L x W x H): 594 x 328 x 235 cm

- Machine comprises two high pulley, two double pulley lat pulldown, two triceps post and two 1/2 cable pulls.
- Natural, precise and supple movement thanks to an extensive biomechanical study.
- Graphic information panel showing the muscles used and the correct positions to adopt.
- Polycarbonate fairing for better protection.

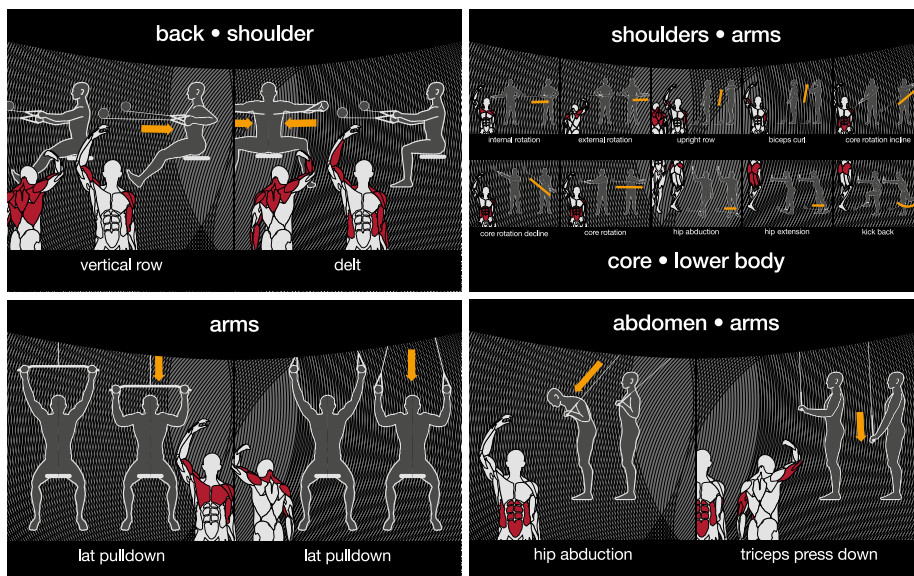

L365_AFT 5 Stations

Dimensions (L x W x H): 490 x 356 x 275 cm

Weight: 890,1 kg

- Laser cutting technology.
- 50mm elevated structure.
- Lasting durability guaranteed.
- Cable Station, where up to eight users can work at the same time.



L360FS_AFT 4 Stations

Dimensions (L x W x H): 190 x 356 x 257 cm

Weight: 657,30 kg

- Pulley support system. Enables all positions.
- Easy handling accessories.



L540_Double Ergolina

Dimensions (L x W x H): 405 x 89,1 x 238 cm

Weight: 433,6 kg

-The multiple training heights offered by the ergolina enable a great variety of exercises for both the upper body and the lower body.

-Design with significant biomechanical study. Guarantees supple, natural movements using full muscle concentration.



L535_Ergolina

Dimensions (L x W x H): 138,5 x 89,1 x 224,7 cm

Weight: 201 kg

-Polycarbonate fairing for high protection. Shock tested. Improved safety against accidents. Easy cleaning.

-Various training heights.



L370_Crossover

Dimensions (L x W x H): 150 x 146 x 218 cm

Weight: 273 kg

Load: 90+90 kg

-Double adjustable pulley, with independent arms and a free rotation movement of 180°.

-Integrated traction bar.

-Accessories included:

- 2 short handles
- 2 long handles
- 1 adjustable wrist and ankle strap
- 1 double cord
- 1 bar

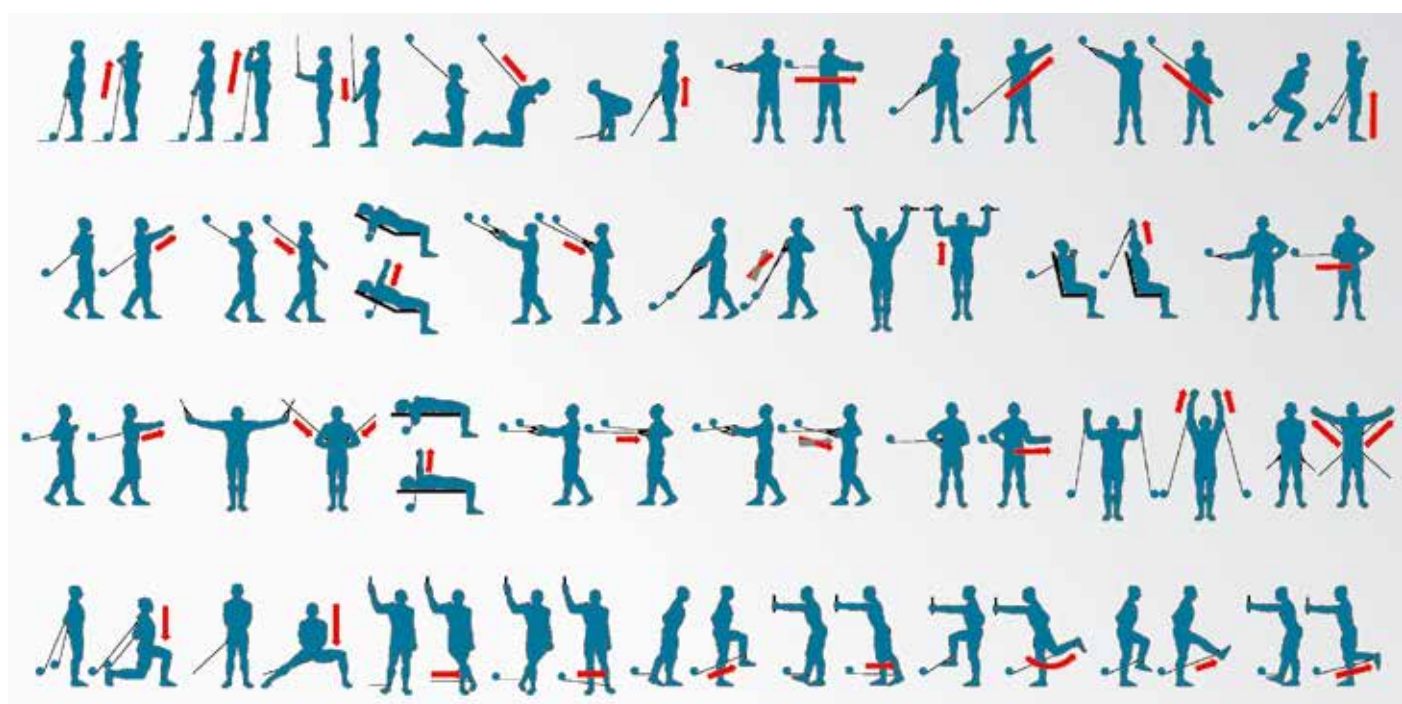

L360_AFT 360

Dimensions (L x W x H): 490 x 356 x 257 cm

Weight: 890,7 kg

- Pulley system. Allows all positions.
- Easy handling accessories.

4 Station

- Length: 190 cm.
- Width (arms folded): 140 cm.
- Width (with arms outstretched): 356 cm.
- Maximum height (with arms in highest position): 257 cm.
- Load (lower pulley): 95 kg.
- Load (ergoline): 65 kg.
- Load (side adjustable pulleys): 65 kg.

V station

- Length: 67 cm.
- Width: 170 cm.
- Height: 236 cm.



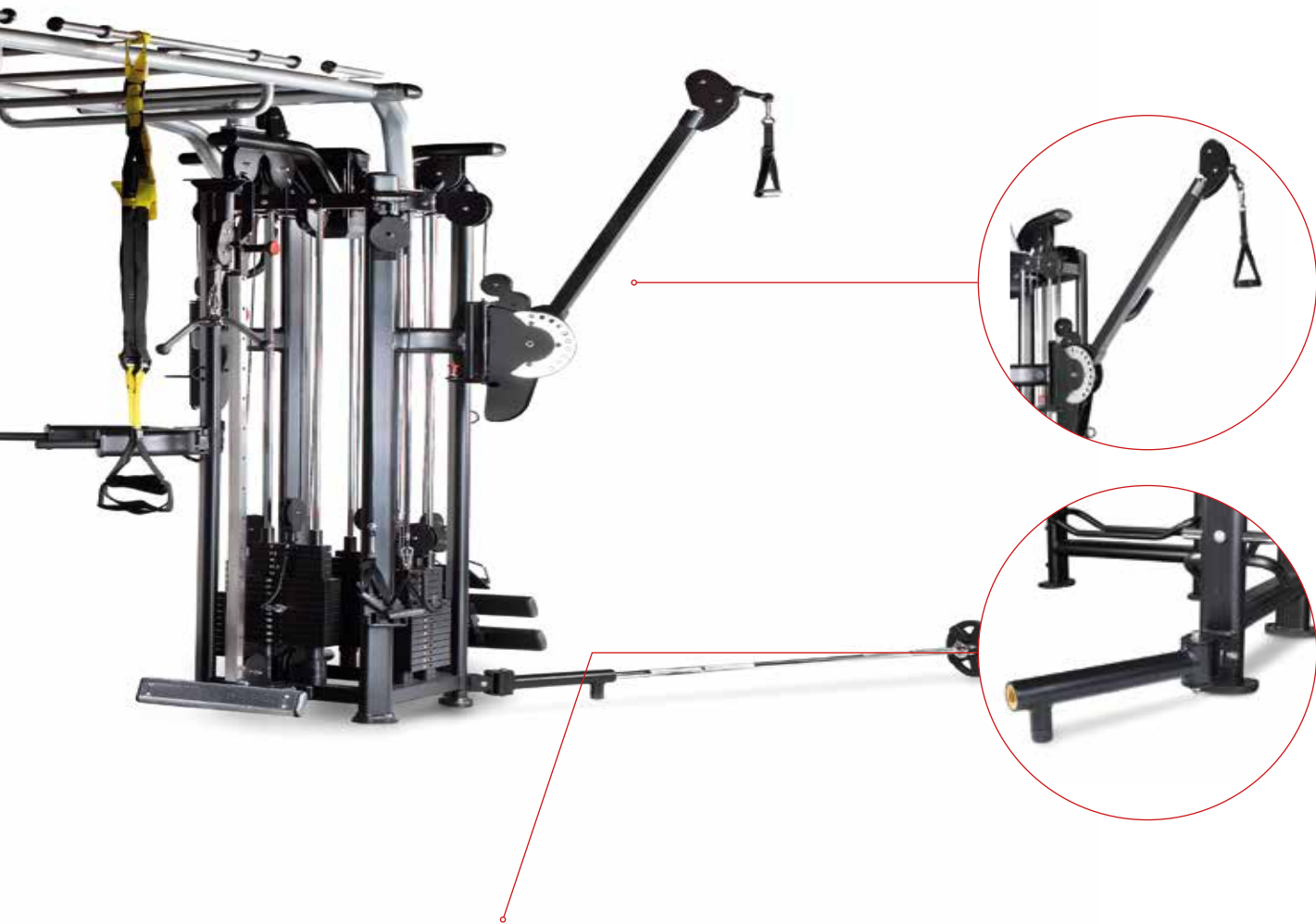

*Accessories are sold separately.

AFT360: An infinite number of training possibilities

Thanks to this innovative concept, users can work in groups of up to 12 people or individually. The most effective and entertaining way to exercise in the gym is called AFT360. The AFT360 is perfect for combining guided loading while giving your members access to the latest training techniques (Strength-Agility-Resistance-Power-Coordination). The AFT360 requires a space of about 25 to 30 m2 and can be used simultaneously by more than ten users.

Архангельск (8182)63-90-72
Астана (7172)727-132
Астрахань (8512)99-46-04
Барнаул (3852)73-04-60
Белгород (4722)40-23-64
Брянск (4832)59-03-52
Владивосток (423)249-28-31
Волгоград (844)278-03-48
Вологда (8172)26-41-59
Воронеж (473)204-51-73
Екатеринбург (343)384-55-89
Иваново (4932)77-34-06

Ижевск (3412)26-03-58
Иркутск (395)279-98-46
Казань (843)206-01-48
Калининград (4012)72-03-81
Калуга (4842)92-23-67
Кемерово (3842)65-04-62
Киров (8332)68-02-04
Краснодар (861)203-40-90
Красноярск (391)204-63-61
Курск (4712)77-13-04
Липецк (4742)52-20-81
Киргизия (996)312-96-26-47

Магнитогорск (3519)55-03-13
Москва (495)268-04-70
Мурманск (8152)59-64-93
Набережные Челны (8552)20-53-41
Нижний Новгород (831)429-08-12
Новокузнецк (3843)20-46-81
Новосибирск (383)227-86-73
Омск (3812)21-46-40
Орел (4862)44-53-42
Оренбург (3532)37-68-04
Пенза (8412)22-31-16
Россия (495)268-04-70

Пермь (342)205-81-47
Ростов-на-Дону (863)308-18-15
Рязань (4912)46-61-64
Самара (846)206-03-16
Санкт-Петербург (812)309-46-40
Саратов (845)249-38-78
Севастополь (8692)22-31-93
Симферополь (3652)67-13-56
Смоленск (4812)29-41-54
Сочи (862)225-72-31
Ставрополь (8652)20-65-13
Казахстан (772)734-952-31

Сургут (3462)77-98-35
Тверь (4822)63-31-35
Томск (3822)98-41-53
Тула (4872)74-02-29
Тюмень (3452)66-21-18
Ульяновск (8422)24-23-59
Уфа (347)229-48-12
Хабаровск (4212)92-98-04
Челябинск (351)202-03-61
Череповец (8202)49-02-64
Ярославль (4852)69-52-93